

EID

How EID improves farm performance

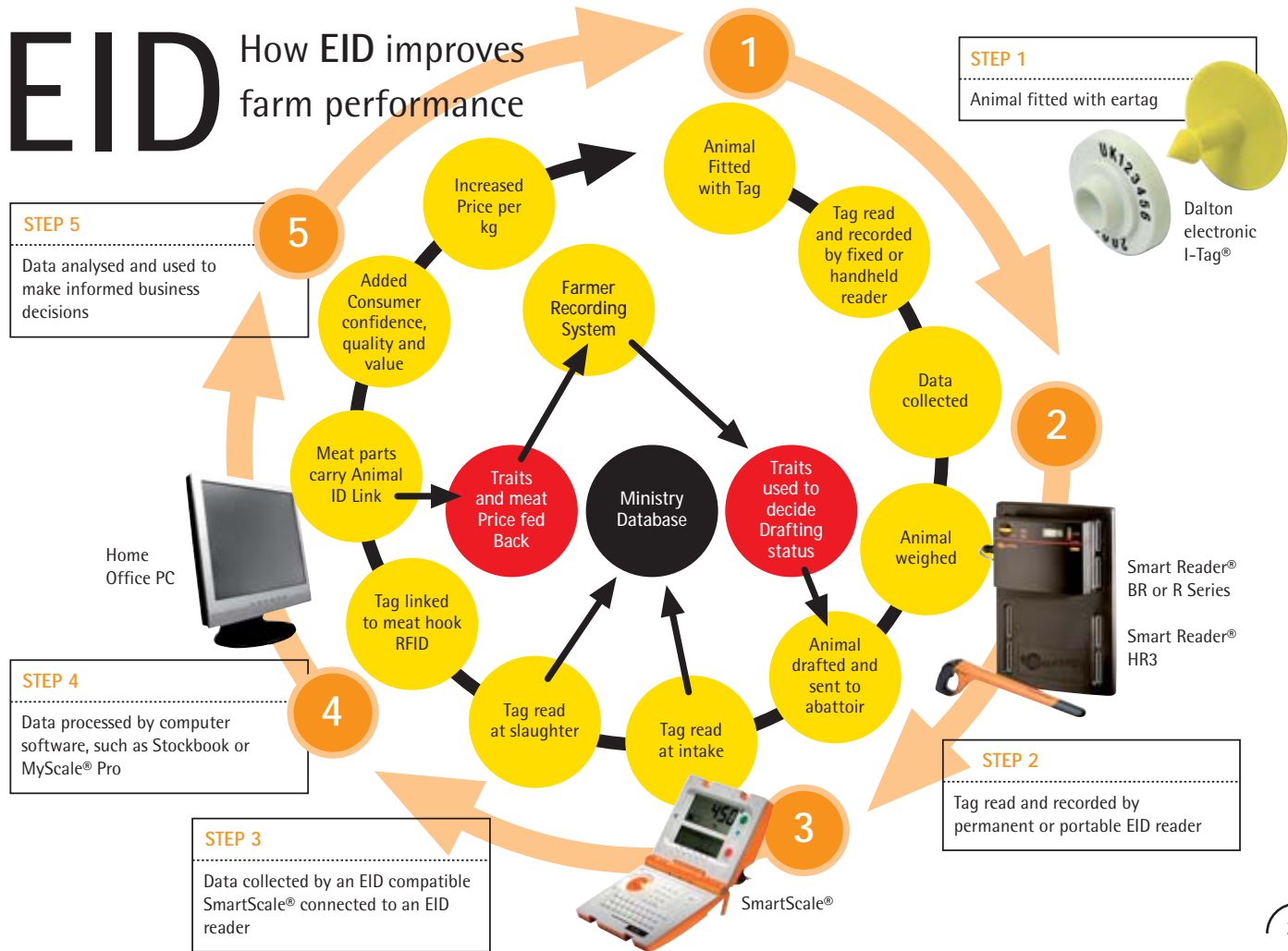

I-Tag[®] Sheep + Goat

▶ DEFRA Approved

● DARDNI Approved

Male part Suretag[®] ST1 **YE WH GN LB OR RE BK PI**

Female part Electronic I-Tag[®] **YE WH GN**

⌚ 24hr Replacements

Ordered before 3 pm despatched same day - see „How to order“ Page 52

📶 HDX or FDX transponder

🔧 Free Applicator with first order

see „How to order“

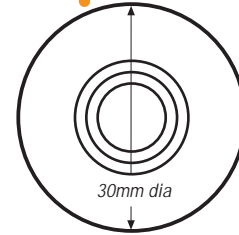

30mm dia

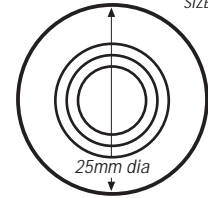

25mm dia



ACTUAL SIZE

* specify open or closed cap when ordering

Closed cap* / non re-usable



I-Tag[®] T3
HDX / FDX



I-Tag[®] T2
HDX / FDX





ACTUAL SIZES

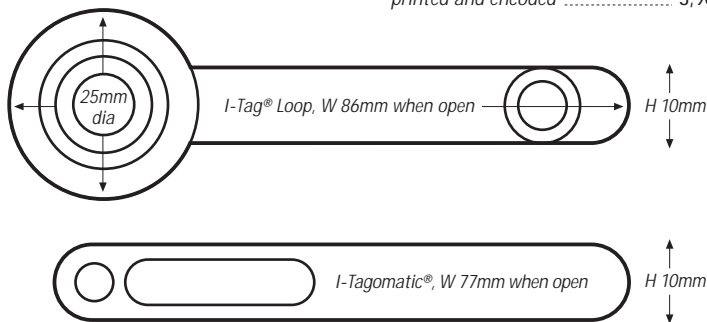
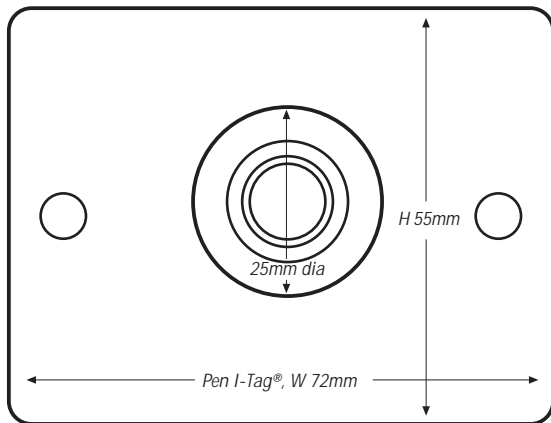

ORDER
CODE

PRICING

I-TAG

S1MFF	I-Tag (FDX) 25mm Button Male & Female, printed & encoded	1,60
S1MFH	I-Tag (HDX) 25mm Button Male & Female, printed & encoded	2,00
DTIF-U	I-Tag (FDX) 30mm Button Male & Female, printed & encoded	1,90
DTIH-U	I-Tag (HDX) 30mm Button Male & Female, printed & encoded	2,30
Minimum order quantity 50 tags		
STPIN	Suretag old plier conversion needle	3,00
ACSUT	Suretag Applicator	18,00
IPOF	I-Tag Loop (FDX) Laser Printed & encoded	1,20
ACLOP	U-Tag + I-Tag Loop Applicator (I-Tag Loop + U-Tag)	12,00
RCKI	Pen I-Tag Pen Location I-Tag (FDX) printed and encoded	3,90

QUESTIONS? FREEPHONE: 0800 838 882

I-Tag® Cattle

- ▶ DEFRA Approved
- DARDNI Approved

I-Tag® Colour Range **YE OR WH LB**

⌚ 24hr Replacements*
Ordered before 3 pm despatched same day - see „How to order“ Page 52

📶 HDX or FDX transponder

£ Free Applicator with first order
see „How to order“



Lifetime Guarantee

Ergonomic handle shaped for hand

I-Tag® (ACITG) Applicator

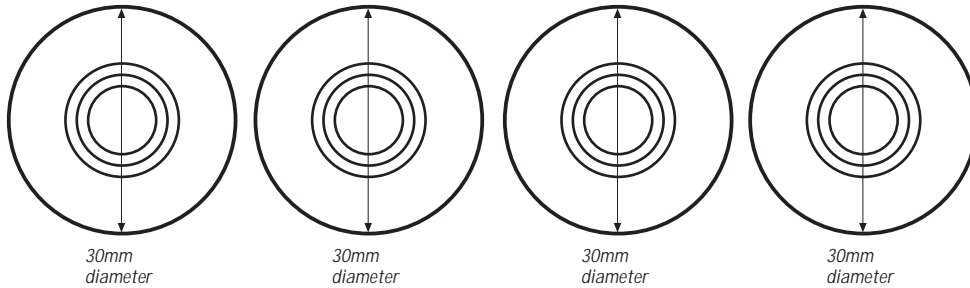

30mm diameter

30mm diameter

30mm diameter

30mm diameter

* specify open or closed cap when ordering

Open cap* / re-usable

Closed cap* / non re-usable

Closed cap*

Open cap*



I-Tag® FDX / HDX

I-Tag® FDX / HDX

I-Tag® FDX

I-Tag® FDX



Supertag® male Button
30mm dia



Startag® male Button
30mm dia



ORDER
CODE

PRICING

ELECTRONIC EARTAGS CATTLE + DEAR

DTIF-U	I-Tag (FDX) 30mm Button Male & Female, printed & encoded	2,00
DTIH-U	I-Tag (HDX) 30mm Button Male & Female, printed & encoded	2,40
ACITC	Applicator I-Tag	18,00
NSIF-U	I-Tag (FDX) 30mm Button printed & encoded.....	2,00

Minimum order quantity 50 tags

ACSTA	Startag / I-Tag Applicator	18,00
STPIN	Old plier conversion needle (Startag).....	3,00



QUESTIONS? FREEPHONE: 0800 838 882

I-Tag[®] Pigs + Sows

▶ DEFRA Approved

● DARDNI Approved

Male part Suretag[®] ST1 **YE WH GN LB OR RE BK PI**

Female part Electronic I-Tag[®] **YE WH GN**

 HDX or FDX transponder

£ Free Applicator with first order
see „How to order“

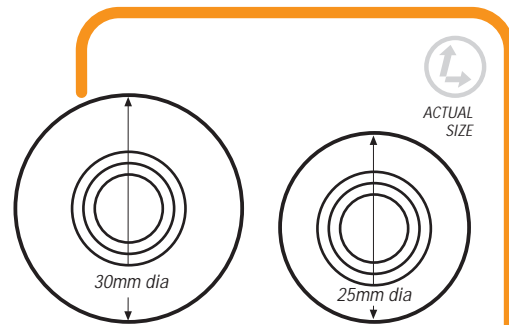

* specify open or closed cap when ordering

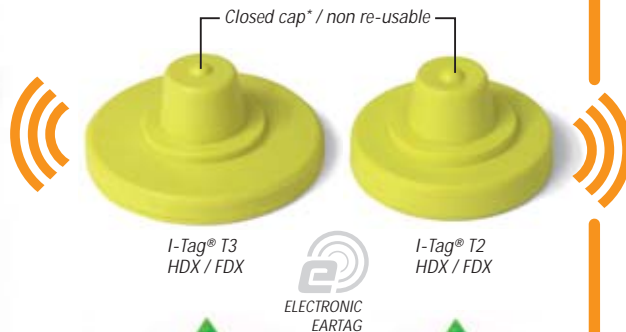



I-Tag® Loop
HDX / FDX

I-Tagomatic®
FDX



I-Tag® Loop packed
in strips of 5 for ease
of use

ACTUAL SIZES

← 25mm dia →

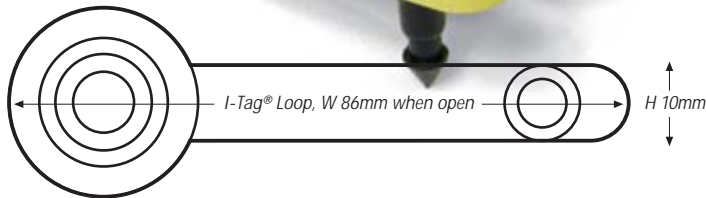

H 10mm



ORDER
CODE

PRICING

ELECTRONIC EARTAGS PIGS

S1MFF	I-Tag (FDX) 25mm Button Male & Female, printed & encoded	1,60
S1MFH	I-Tag (HDX) 25mm Button Male & Female, printed & encoded	2,00
DTIF-U	I-Tag (FDX) 30mm Button Male & Female, printed & encoded	1,90
DTIH-U	I-Tag (HDX) 30mm Button Male & Female, printed & encoded	2,30
STPIN	Suretag old plier conversion needle	3,00
ACSUT	Suretag Applicator	18,00
IPOF	I-Tag Loop (FDX) Laser Printed & encoded	1,20
ACUTG	I-Tag Loop Applicator	12,00
DOE	I-Tagomatic Electronic Tag (FDX) printed	0,80
DOE2	Double I-Tagomatic Set E tag + Visual Tag combination	0,92
ACITA	I-Tagomatic Applicator	12,00

Minimum order quantity 50 tags

SmartReader®



Handheld Reader

- ▶ Portable, light and easy to use
- Memory for 5,000 tags
- Use out of the box
- £ Software included



HDX and FDX-B compatible

Graphic LED display



ELECTRONIC SYSTEMS

Li-ION Rechargeable



12v DC Power Supply
plus MyScale Pro
Management
Software included



Technical Data

<i>Case Construction:</i>	Polycarbonate ABS
<i>Frequency:</i>	134.2 KHz
<i>Transponder Types:</i>	HDX compatible (ISO 11784/5) FDX-B compatible (ISO 11784/5)
<i>Memory:</i>	5,000 tags
<i>Reading range:</i>	approx. 25 to 35cm, tag dependant
<i>Communication:</i>	serial RS232 + Bluetooth (class 1-100m)
<i>Power supply:</i>	Li-ION Rechargeable 6+ hours of continuous reads
<i>Power input:</i>	12V DC for charging
<i>Protection level:</i>	IP 66
<i>Display:</i>	„OLED“ 126 x 64 pixels
<i>Temperature range:</i>	-20°C to +85°C
<i>Language:</i>	English
<i>Dimensions:</i>	L x W: 600 x 90mm
<i>Weight:</i>	790g
<i>Included in the box:</i>	Reader, CD Manual, MyScale Pro Mngt. Software, 12v DC intern. Power Supply
<i>Certifications:</i>	CE

Some features of the Gallagher Portable Reader:

- Lightweight, Robust, ergonomic with hand guard
- Read Alert via Vibration, light on snout and Sound
- Graphic LED display shows;
 - Number of tags read in current session
 - Total Number of tags numbers stored
 - Unique EID number of last tag
 - Battery level charge
 - Reader in record data or transfer mode
- Compatible with SmartScale® and other brands
- Long (600mm) reader snout for easier reading

ORDER
CODE

PRICING

	GALLAGHER ELECTRONIC HANDHELD READER
GRGRH	Gallagher® RS232 Handheld Reader HR1, ISO HDX/FDX..... 760,00
GRGBH	Gallagher® Bluetooth Handheld Reader HR3, internal battery ISO HDX/FDX..... 860,00
GRGTH	Gallagher® Bluetooth Handheld Reader HR4, internal battery ISO HDX/FDX..... POA
GRGSO	Interface Software for Gallagher® handheld reader Included

Download full datasheets
at www.daltonid.com

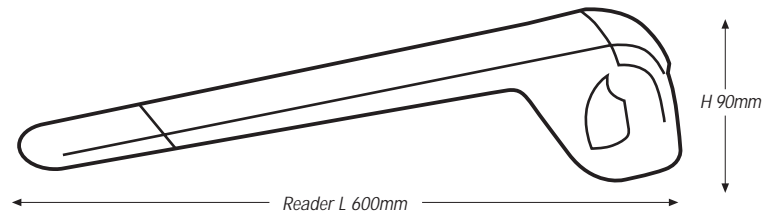

BioControl

HHR 3000 PRO V2

- ▶ Lightweight, Robust, Ergonomic
- Memory for 1,000 tags
- Use out of the box
- £ Uploadable application software



„Condom“ covers charging and USB socket makes it watertight and absorbs shocks

Good readable display with clear lights



Technical Data

RFID

134.2 kHz

Reads HDX and FDX-B transponder according to ISO 11784/11785

Synchronises to stationary readers according to ISO 11785 clause 6

Advance Digital Decoding technology (ADD)

Read range

50 cm with HDX ear tag

30 cm with FDX-B ear tag

Limited dynamic reading with Panel Antenna.

Use for reading constrained animal only (e.g. weighing)

Housing (with fixed long antenna)

Dimensions: 825 x 120 x 46 mm

Weight: 775 gr.

Battery: 2000 mAh capacity, sufficient for 1 day reading

Dust and water: IP65

On-board computer

Non-volatile, 512 Kbytes for animal database and application program

Real-time clock for logging time/date stamp

Upload application program

Interface

Standard USB 2.0

Optional Bluetooth 1.2, RS232 and GPRS

Supplied with basic PC program to exchange data between PC and HHR 3000 Pro V2 (WIN98, 2000, XP, Vista)

Approvals and certifications

FCC *complies with Part 15 of the FCC rules*

EU-JRC *certificate 161/07*

CE *meets EN50082-1 and EN50022*

ORDER
CODE

PRICING

BIOCONTROL

ELECTRONIC HANDHELD READERS

BC012	BioControl® HHR3000 Pro Bluetooth, RS232 with short antenna fitted.....	870,00
BC019	BioControl® HHR3000 Pro Bluetooth, RS232 with short loop antenna fitted.....	880,00
BC011	BioControl® HHR3000 Pro Bluetooth, RS232 with long antenna fitted.....	890,00
BC020	BioControl® HHR3000 Pro Bluetooth, RS232 with medium antenna fitted.....	880,00
BC007	BioControl® HHR3000 pro V2 long antenna only (60cm).....	100,00
BC010	BioControl® HHR3000 Pro V2 extra long antenna only (115cm).....	150,00
BC016	BioControl® GPRS Option for all readers (SIM card not included), Add	150,00
BCAPP	Interface Software for BioControl® HHR reader.....	Included

FEATURES

The HHR 3000 Pro V2 is an easy to operate Handheld Reader for ISO 11784/11785 transponders. It is designed for on-farm use under "real life" conditions and combines great reading performance, enhanced computer features with ease of operation.

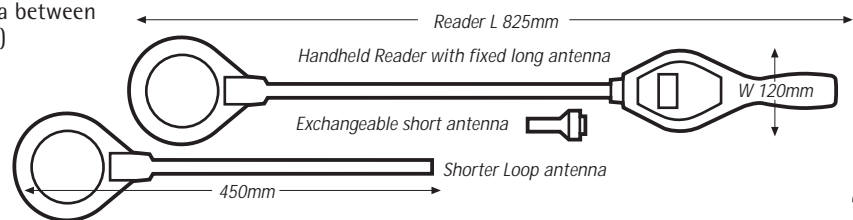

LiveTrack®

QUESTIONS? FREEPHONE: 0800 838 882

- ▶ Lightweight, Robust, Ergonomic
- Memory for 10,000 tags
- Use out of the box
- £ LiveTrack software included

*Easy to use out of the box:
the Syscan Reader is an ideal
solution for feedlots, transporters,
auction houses and more*



650mm reader snout
for easier reading



Handheld Reader



Read Alert via
Vibration and Sound

7.4v Li-ION
Rechargeable

HDX and FDX-B
compatible



*Included in the box: Quick start guide, Reader,
Livetrack manager software, CD Manual,
Hand strap, Serial cable & 12v DC international
Power Supply*

Technical Data

<i>Case Construction:</i>	Polycarbonate ABS
<i>Frequency:</i>	134.2 KHz
<i>Transponder Types:</i>	HDX compatible (ISO 11784/5) FDX-B compatible (ISO 11784/5)
<i>Memory:</i>	10,000 tags
<i>Reading range:</i>	approx. 25 to 35cm, tag dependant
<i>Communication:</i>	serial RS232 + Bluetooth (class 1-100m)
<i>Power supply:</i>	7.4v Li-ION Rechargeable 6+ hours of continuous reads 12V DC for charging
<i>Power input:</i>	12V DC for charging
<i>Protection level:</i>	IP 66
<i>Display:</i>	„OLED“ 126 x 64 pixels
<i>Temperature range:</i>	-20°C to +85°C
<i>Language:</i>	English, French, Spanish, German
<i>Dimensions:</i>	L x W x H: 650 x 100 x 30mm
<i>Weight:</i>	720g
<i>Included in the box:</i>	Reader, Quick Start guide, LiveTrack manager software, CD Manual Hand strap, Serial cable, 12v DC international Power Supply
<i>Certifications:</i>	CE, IC, FCC, C-Tick

Some features of the Syscan LiveTrack® Reader:

- Lightweight, Robust, Ergonomic
- Read Alert via Vibration and Sound
- Compatible with SmartScale® 500, 700, 800 and other brands
- Long (650mm) reader snout for easier reading

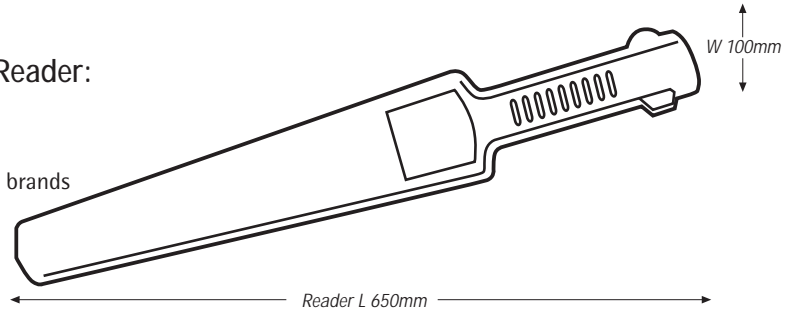
ORDER
CODE

PRICING

SYSCAN ELECTRONIC HANDHELD READER

GRSWL	Syscan® Bluetooth Wand Reader, Long version ISO HDX/FDX 805,00
GRSSO	Management Software for Syscan® SS1 + 2.....Included

Download full datasheets
at www.daltonid.com

PanelReader



Animal Management

- ▶ Automatic Tuning every session
- Memory for 20,000 tags
- Easy to install yourself
- £ Included Software and accessories



Switchable options

> 1.2m Reading range

Wireless synchronisation and software diagnosis

HDX and FDX-B compatible

Controller/reader can be un-hooked for easy storage

Steel Reinforced mounting positions



QUESTIONS? FREEPHONE: 0800 838 882

Technical Data

Frequency:	134.2 KHz
Transponder Types:	HDX compatible (ISO 11784/5) FDX-B compatible (ISO 11784/5)
Memory:	20,000 tags
Display:	2 x 10 OLED that displays over 30 messages
Reading range:	> 1.2m
Interfaces:	Bluetooth class 1 (100m) + serial
Power supply:	Li-ION Rechargeable providing 8 hours of continuous reading
Protection level:	IP 67
Temperature range:	-25°C to +85°C

Features of the Gallagher "R" Panel Reader:

- Automatic Tuning every session
- 12 volt Adapter included
- Controller/Reader can be un-hooked from Panel for easy storage or attached to another panel
- Additional Antenna Panels can be purchased for multiple sites
- Wireless Synchronisation
- Tough one piece fully sealed Antenna Panel available in 600mm or 1300mm heights
- Full range of accessories + software
- Steel Reinforced mounting positions
- Switchable Options
- Plug + Play with Gallagher SmartScale®



Full range of accessories, installation material and Gallagher MyScale® Pro software included

Additional Features of the "BR" Model:

- Battery providing 8 hours use
- Battery charge indicator + re-charge unit
- 20.000 Tag Memory
- Counter with Multiple Sessions
- Optional Bluetooth
- Water Proof / Air Tight to IP67 for harsh environments

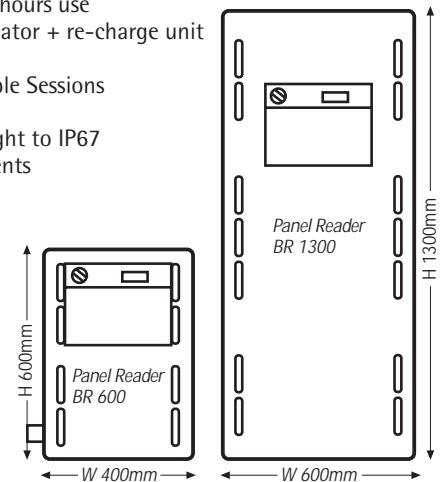
ORDER
CODE

PRICING

GALLAGHER ELECTRONIC PANEL WALK-BY READERS

GFGBR	Gallagher® Reader Controller BR, ISO Auto tuning, int. battery.....1,950,00
GFP64	Panel Antenna 600 x 400mm.....499,00
GFP13	Panel Antenna 1300 x 800.....750,00
GFGSO	Diagnostic Configurator Software.....Included
GFGEX	Extension Kit/Bracket (Raise and reverses reader unit)....21,50
GFGDU	Bluetooth Dongle USB.....16,00
GFGDR	Bluetooth Dongle RS232.....17,00